



# G-SL-715

Ranger Domestic AC Sliding Gate Motor



**RANGER**



Ranger Sliding Gate Motor are designed to smartly control all types of residential sliding gates. Come out as innovative design, reliable operation, high performance and diversity choices.

Ranger Sliding Gate are an excellent choice for residential driveway gate automation when the site has steep grades prohibiting the use of a swing gate, or sites where there is limited space for swing gates to operate freely and where higher security is required.



### **Intensive Use**

Designed for installation in domestic settings, or anywhere that requires maximum reliability with intensive use.



### **Built-in Control Unit**

With built-in control panel, with built in receiver, guarantees the stable and highest performance.



### **Key Release System**

Aluminium release handle with protected lock and customized release key.



### **Magnetic Limit Switch**

This model's sliding gates come with magnetic limit switch selection.



# G-SL-715

## Ranger Domestic AC Sliding Gate Motor



### RANGER



#### Auto Close Function

Automatic closing with adjustable time delay, and push button override.



#### Soft Start & Slow Close

Reliable, safe performance and stable operation.



#### Auto Reverse on Obstacle

Smart version with auto-reverse when hitting obstacle during closing.

# 1,500<sup>KG</sup>

#### Maximum Gate Weight

Maximum support gate weight up to 1,500kg

\*All image and specification is subject to change without prior notice.



Technical Data	G-SL-715-M	G-SL-715-M-M
Limit Switch	Magnetic	Magnetic (Motor only w/o Control Panel)
Power Supply	AC220V/50Hz ; 110V/60Hz	
Power Consumption	50Hz	
Motor Power	400W	
Output Torque	22 N.m	
Output Shaft Height	50mm	
Gate Moving Speed	11-13m/min	
Maximum of Remote Control	25	
Frequency	433.92Mhz	
Work Duty	S2 15min	
Noise	≤58dB	
Working Temperature	-20°C~70°C	
Maximum Gate Weight	1,500Kg	

#### Standard Colours



Platinum Grey  
(Similar to RAL7036)

#### Ordering Info

Model	Motor Configuration
G-SL-715-M	Magnetic Limit Switch
G-SL-715-M-M	Magnetic (Motor only w/o Control Panel)

G-SL-715-M, G-SL-715-M-M



Control Panel

\*For G-SL-715-M-M Model only



Transmitter &  
Receiver



Gear Rack



Base Plate  
(Optional)

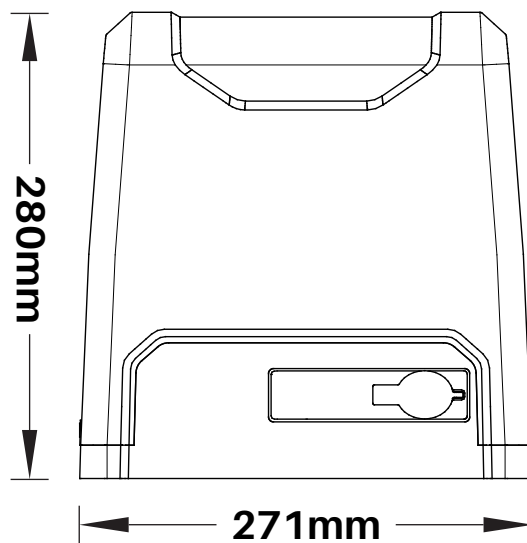
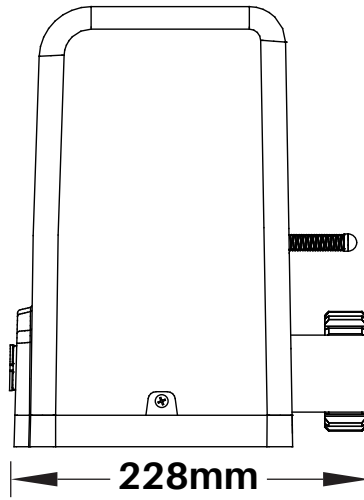

- 1. Gate Opener
- 2. Wireless Keypad (optional)
- 3. Gate
- 4. Infrared Sensor (optional)
- 5. Alarm lamp (optional)
- 6. Safety stop block (optional)
- 7. Gear rack
- 8. Remote Control

